

# FREESTANDING LABEL HOLDER

A multi-functional, flexible way to display information near artworks or artifacts, the Freestanding Label Holder has a durable anodised finish and a thin extruded aluminium backplate with an acrylic cover. It has the advantage of being extremely slim, robust, cost effective and comes with a permanently attached aluminium foot.

Our flexible Freestanding Label Holder is equally at home in museums and galleries as it is in reception areas in commercial offices, hospitality environments and high-end retail establishments for displaying price and product information.

CODE:  
LF11

Scan for  
more info:



## PRODUCT SPECIFICATION

<b>Function</b>	Freestanding Label/Caption Holder
<b>Dimensions</b>	Landscape and portrait options from 150x100mm up to A3 (full details on-line). Label angle 45°.
<b>Material</b>	Extruded aluminium back plate, attached aluminium foot and acrylic front cover.
<b>Finish</b>	●
<b>Customise</b>	Available in bespoke lengths and RAL colours

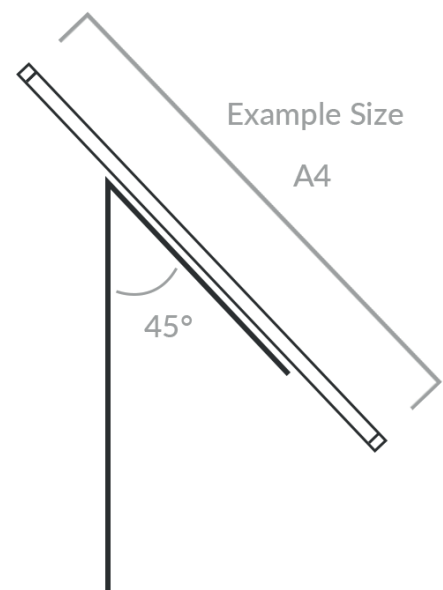

Museum of Somerset, Taunton, UK.